

FIITJEE
ALL INDIA TEST SERIES
JEE (Advanced)-2025
PART TEST – II
PAPER –1
TEST DATE: 08-12-2024

Time Allotted: 3 Hours

Maximum Marks: 180

General Instructions:

- The test consists of total 51 questions.
- Each subject (PCM) has 17 questions.
- This question paper contains **Three Parts**.
- **Part-I** is Physics, **Part-II** is Chemistry and **Part-III** is Mathematics.
- Each **Part** is further divided into **Two Sections: Section-A & Section-B**.

Section – A (01 – 04, 18 – 21, 35 – 38): This section contains **TWELVE (12)** questions. Each question has **FOUR** options. **ONLY ONE** of these four options is the correct answer.

Section – A (05 –07, 22 – 24, 39 – 41): This section contains **NINE (9)** questions. Each question has **FOUR** options. **ONE OR MORE THAN ONE** of these four option(s) is(are) correct answer(s).

Section – A (08 – 11, 25 – 28, 42 – 45): This section contains **TWELVE (12)** Matching List Type Questions. Each question has **FOUR** statements in **List-I** entries (P), (Q), (R) and (S) and **FIVE** statements in **List-II** entries (1), (2), (3), (4) and (5). The codes for lists have choices (A), (B), (C), (D) out of which, **ONLY ONE** of these four options is correct answer.

Section – B (12 – 17, 29 – 34, 46 – 51): This section contains **EIGHTEEN (18)** numerical based questions. The answer to each question is a **NON-NEGATIVE INTEGER VALUE**.

MARKING SCHEME

Section – A (Single Correct): Answer to each question will be evaluated according to the following marking scheme:

Full Marks	:	+3	If ONLY the correct option is chosen.
Zero Marks	:	0	If none of the options is chosen (i.e. the question is unanswered);
Negative Marks	:	-1	In all other cases.

Section – A (One or More than One Correct): Answer to each question will be evaluated according to the following marking scheme:

Full Marks	:	+4	If only (all) the correct option(s) is (are) chosen;
Partial Marks	:	+3	If all the four options are correct but ONLY three options are chosen;
Partial marks	:	+2	If three or more options are correct but ONLY two options are chosen and both of which are correct;
Partial Marks	:	+1	If two or more options are correct but ONLY one option is chosen and it is a correct option;
Zero Marks	:	0	If none of the options is chosen (i.e. the question is unanswered);
Negative Marks	:	-2	In all other cases.

Section – B: Answer to each question will be evaluated according to the following marking scheme:

Full Marks	:	+4	If ONLY the correct numerical value is entered at the designated place;
Zero Marks	:	0	In all other cases.

Physics

PART – I

SECTION – A

(One Options Correct Type)

This section contains **FOUR (04)** questions. Each question has **FOUR** options (A), (B), (C) and (D). **ONLY ONE** of these four options is the correct answer.

1. Three infinite long current carrying wires are kept along z-axis carrying current I_0 , $2I_0$ and $3I_0$ respectively as shown in the figure.

All the wire intersecting a circle of radius r . The $\int_B^C \vec{B} \cdot d\vec{\ell}$ for the path

BC will be ($\theta = 30^\circ$)

- (A) zero
 (B) $\frac{\mu_0 I}{24}$
 (C) $\frac{\mu_0 I}{12}$
 (D) $\frac{\mu_0 I}{4}$

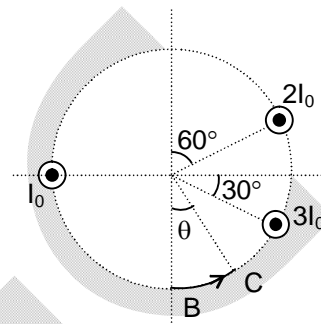

2. A horizontal smooth groove is formed inside of a solid sphere of radius $R = 1\text{ m}$ and a charge $Q = 1\mu\text{C}$ is uniformly distributed in the sphere in whole volume. The sphere rotates with constant angular velocity $\omega = 1\text{ rad/s}$ as shown in the figure. A charge particle of mass $m = 1\text{ gm}$ and charge $q = \left(\frac{1}{3}\right)\mu\text{C}$ is released at rest just right of the centre along the groove. The speed with which the ball leaves the groove is

- (A) 2 m/s
 (B) $\sqrt{3}$ m/s
 (C) $\sqrt{5}$ m/s
 (D) 1 m/s

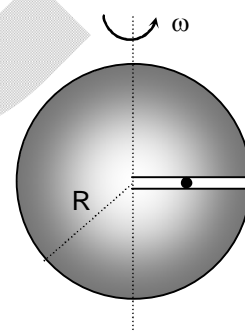

3. In a potentiometer experiment setup, the length of uniform wire is L as shown. When switch S_2 is open, the galvanometer shows no deflection at length $\ell = \frac{L}{2}$ and when switch S_2 is

closed, the galvanometer shows no deflection for $\ell = \frac{5L}{12}$. The internal resistance of 6V battery r and the emf of other battery E are respectively.

- (A) 3Ω , 8V
 (B) 2Ω , 12V
 (C) 2Ω , 24V
 (D) 3Ω , 12V

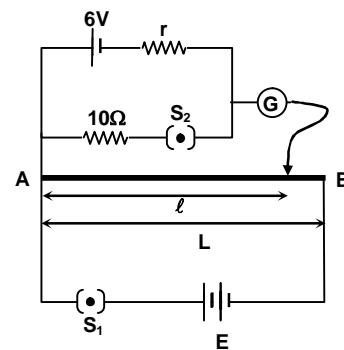

4. Figure shows the V-T graph for adiabatic compression curve for 2 moles of an ideal gas. The Bulk modulus of elasticity of gas at point P will be

- (A) $R\left(1 + \frac{T_0}{V_0}\right)$
 (B) $2R\left(1 + \frac{T_0}{V_0}\right)$
 (C) $\frac{2RT}{V_0}$
 (D) $\frac{RT}{2V_0}$

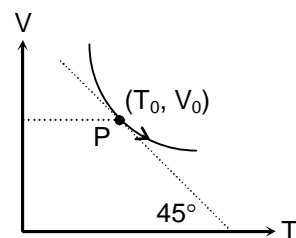

SECTION – A

(One or More than one correct type)

This section contains **THREE (03)** questions. Each question has **FOUR** options (A), (B), (C) and (D). **ONE OR MORE THAN ONE** of these four option(s) is (are) correct answer(s).

5. Four points charges of negligible masses $+q$, $+q$, $-q$ and $-q$ are embedded inside of a solid sphere of mass m and radius R symmetrically. The distance of each charge from the centre is $a\sqrt{2}$. Initially sphere is resting on a horizontal surface as shown in the figure. Now an electric field \vec{E} is switched on, the sphere starts rolling without sliding. Find the correct option(s).

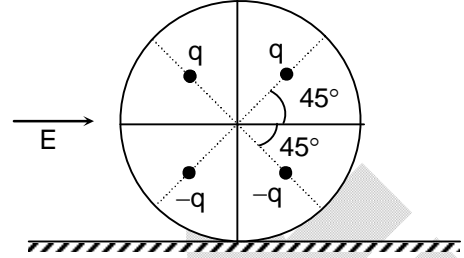

- (A) Velocity of sphere when sphere rotates by $\frac{\pi}{2}$ is $\sqrt{\frac{40qaE}{7m}}$
- (B) Frictional force during the motion is static and constant.
- (C) Frictional force acting on sphere, when sphere is rotated by $\left(\frac{\pi}{2}\right)$ will be zero.
- (D) The sphere will oscillate simple harmonically.
6. The total energy of a black body radiation source is collected for one minute and used to heat water. The temperature of the water increases from 20°C to 21°C . If the absolute temperature of the black body is doubled and the experiment is repeated, which of the following statement(s) would be most nearly correct?
- (A) The temperature of the water would increase from 20°C to a final temperature of 28°C
- (B) The temperature of the water would increase from 20°C to a final temperature of 36°C
- (C) Rate of heat emission by the body increases 4 times
- (D) Rate of heat emission by the body increases 16 times

7. An AC source $V = 200\sqrt{2} \sin\left(\omega t + \frac{\pi}{4}\right)$ is connected across a circuit where capacitive reactance is $X_C = 10\Omega$, $R = 4\Omega$ and inductive reactance $X_L = 3\Omega$ as shown. Mark the correct answers.

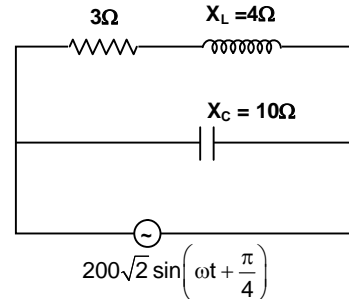

- (A) Instantaneous current in the branch having capacitor C will be $20\sqrt{2} \sin\left(\omega t + \frac{\pi}{4}\right)$
- (B) Instantaneous current in the branch having capacitor C will be $20\sqrt{2} \sin\left(\omega t + \frac{3\pi}{4}\right)$
- (C) Potential drop across X_L will be 160 V
- (D) Potential drop across R will be 120 V

SECTION – A
(Matching List Type)

This section contains **FOUR (04)** Matching List Type Questions. Each question has **FOUR** statements in **List-I** entries (P), (Q), (R) and (S) and **FIVE** statements in **List-II** entries (1), (2), (3), (4) and (5). The codes for lists have choices (A), (B), (C), (D) out of which **ONLY ONE** of these four options is correct answer.

8. Initially switches S_1 and S_2 are disconnected and capacitor of capacitance $2C$ carries charge q_0 another capacitor of capacitance ' C ' is uncharged and there is no current in both the coil of inductance L and $2L$ respectively. Switch S_1 is closed and the capacitor $2C$ starts discharge. The moment when the current in the coil reaches to maximum value the switch S_2 is instantly connected. Now match the **List-I** with **List-II**.

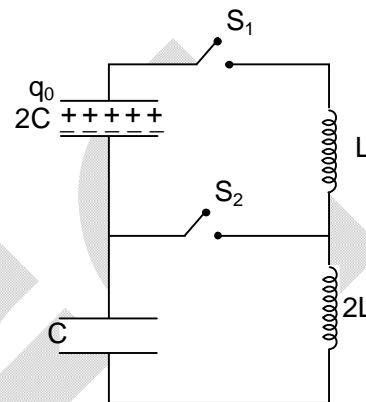

List –I		List –II	
(P)	Maximum current I_0 in the circuit before ' S_2 ' is connected	(1)	$\frac{q_0}{3} \frac{1}{\sqrt{LC}}$
(Q)	Maximum current I_1 through L after switch ' S_2 ' is connected	(2)	$\frac{q_0}{3} \frac{\sqrt{5}}{\sqrt{LC}}$
(R)	Maximum current I_2 both $2L$ after switch ' S_2 ' is connected	(3)	$\frac{q_0}{\sqrt{2LC}}$
(S)	Maximum current I_3 through ' S ' after switch ' S_2 ' is closed	(4)	$\frac{q_0}{3\sqrt{2LC}}$
		(5)	$\frac{q_0}{3} \frac{\sqrt{5}}{\sqrt{2LC}}$

The correct option is:

- (A) (P) → (4) (Q) → (5) (R) → (1) (S) → (3)
 (B) (P) → (3) (Q) → (2) (R) → (5) (S) → (4)
 (C) (P) → (3) (Q) → (2) (R) → (2) (S) → (4)
 (D) (P) → (2) (Q) → (5) (R) → (1) (S) → (3)
9. In the following network capacitance of each capacitor is $11 \mu\text{F}$. Initially all capacitors were uncharged. Energy stored in C_5 capacitor is $22 \mu\text{J}$ after switch S is connected. Now match the **List-I** with **List-II**.

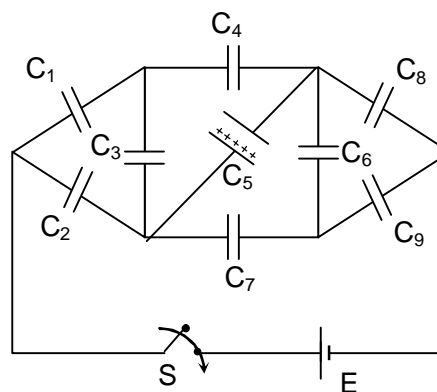

List –I		List –II	
(P)	emf E of battery is K_1 volt. Find value of K_1	(1)	44
(Q)	Charge stored in the capacitor C_8 is $4K_2$ micro-coulomb. Find the value of K_2 .	(2)	10
(R)	Charge drawn from battery is $\frac{11K_3}{3}$ micro-coulomb. Find the value of K_3 .	(3)	11
(S)	Energy drawn from battery is $\frac{55K_4}{6}$ micro-joules. Find the value of K_4 .	(4)	22
		(5)	88

The correct option is:

- (A) (P) \rightarrow (3) (Q) \rightarrow (2) (R) \rightarrow (1) (S) \rightarrow (4)
 (B) (P) \rightarrow (3) (Q) \rightarrow (2) (R) \rightarrow (5) (S) \rightarrow (4)
 (C) (P) \rightarrow (2) (Q) \rightarrow (3) (R) \rightarrow (4) (S) \rightarrow (5)
 (D) (P) \rightarrow (2) (Q) \rightarrow (3) (R) \rightarrow (4) (S) \rightarrow (1)

10. In the circuit shown the resistance R is kept in a chamber whose temperature is 20°C which remains constant. The initial temperature and resistance of R is 50°C and 30Ω respectively. The resistance of resistor changes with temperature at the rate of $1\ \Omega/^\circ\text{C}$ and the temperature of resistance decreases according to Newton's law of cooling and the rate of decrease of temperature of R is $\frac{(\ln 3)}{100}$ times the temperature difference from surrounding. At $t = 0$ both the switch S_1 and S_2 are closed.

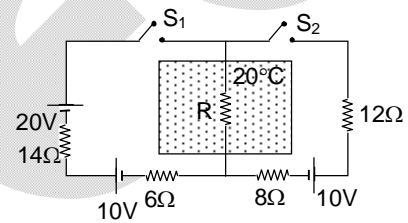

List –I		List –II	
(P)	The value of R (in Ω) for which power dissipation in it is maximum is	(1)	6
(Q)	Temperature of R when power dissipation in it is maximum is $T^\circ\text{C}$ then $\frac{T}{5}$ is	(2)	10
(R)	Time after which power dissipation in it is maximum is t sec. then $\frac{t}{20}$ is	(3)	1
(S)	Current (in Amp.) through 20 V battery when power dissipation in R is maximum is	(4)	4
		(5)	5

The correct option is:

- (A) (P) \rightarrow (3) (Q) \rightarrow (1) (R) \rightarrow (2) (S) \rightarrow (4)
 (B) (P) \rightarrow (2) (Q) \rightarrow (1) (R) \rightarrow (5) (S) \rightarrow (3)
 (C) (P) \rightarrow (2) (Q) \rightarrow (2) (R) \rightarrow (5) (S) \rightarrow (3)
 (D) (P) \rightarrow (2) (Q) \rightarrow (5) (R) \rightarrow (1) (S) \rightarrow (3)

11. For the given four thermodynamic system match **List-I** to **List-II**.

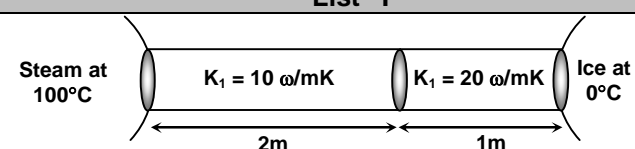
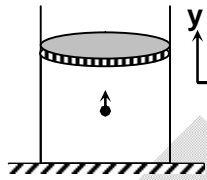
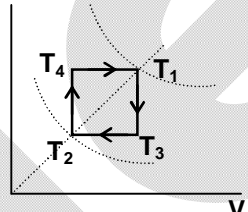
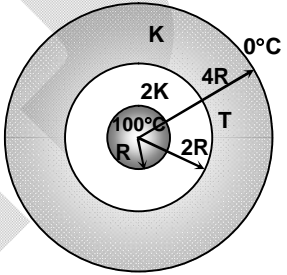
List -I		List -II	
(P)	 <p>At steady state two conducting rods are connected across steam reservoir and ice reservoir. Curved surface of rod is thermally insulated. Area of cross section of both the rods are same, then the temperature of junction in Celsius scale is</p>	(1)	75
(Q)	<p>1 mole of H₂ molecules are kept in a chamber of area of cross section 100 cm² and length 10 cm as shown. The y-component of velocity of molecule is 600 m/s. The pressure of the gas is observed $k \times 10^4$ N/m. Find the value of k.</p> 	(2)	25
(R)	<p>Between two isothermals we have a cyclic process for 1 mole of an ideal gas as shown. Temperature of isotherms are T₁ = 127°C and T₂ = 16°C. The work done by gas in joules is (Take R = $\frac{25}{3}$ J/mol-K)</p> 	(3)	50
(S)	<p>Two thick concentric spherical shell of inner, outer radius R and 2R and inner, outer radius 2R, 4R are as shown in the figure. At steady state the temperature of innermost surface is 100°C and temperature of outermost surface is 0°C. The thermal coefficients are 2K and K respectively. The temperature T of junction in Celsius scale is</p> 	(4)	20
		(5)	24

The correct option is:

- (A) (P) → (4) (Q) → (5) (R) → (2) (S) → (1)
- (B) (P) → (3) (Q) → (2) (R) → (5) (S) → (4)
- (C) (P) → (4) (Q) → (2) (R) → (1) (S) → (3)
- (D) (P) → (4) (Q) → (5) (R) → (1) (S) → (3)

SECTION – B

(Numerical Answer Type)

This section contains **SIX (06)** Numerical based questions. The answer to each question is a **NON-NEGATIVE INTEGER VALUE**.

12. The wavelength at which the spectral emissive power of a black body (at a temperature T) is maximum is given by λ_m . If the temperature of the body is increased by 1K, λ_m is decreases by $\left(\frac{1}{2}\right)$ percent. The temperature T of the black body is Kelvin.

13. A charge q is located somewhere inside of a hemispherical shell such that the depth of charge from the base of shell is 'd'. It is found that the flux associated with the curved surface of shell is $\frac{q}{3\epsilon_0}$. If an another charge $2q$ is placed at a height d as shown the associated flux through curved surface was observed $\frac{Kq}{3\epsilon_0}$. Find the value of K .

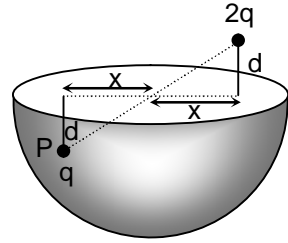

14. Electrostatic potential in a gravity free region varies with x as shown in the figure. A charge $q = -20\mu\text{C}$ and mass 2kg is released from rest at origin. The acceleration of charge particle at $x = 25\text{ cm}$ is $k\text{ m/s}^2$. Find the value of k .

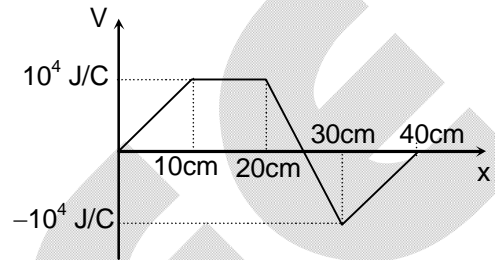

15. A 1 kW electric kettle contains 2 liter water at 27°C . The kettle is operated for 10 minutes. If heat is lost to surrounding at a constant rate 160 J/s . Then the temperature attained by water in 10 minute will be (specific heat capacity of water = $4.2\text{ kJ/kg}^\circ\text{C}$)

16. V-T graph for a cyclic process for 1 mole of monoatomic gas is shown in the figure. The slope of graph in process AB varies as $\frac{C}{P}$. Where k is a constant and P is the pressure of the gas. The work done by the gas in the process of the gas is mC . Find the value of m .

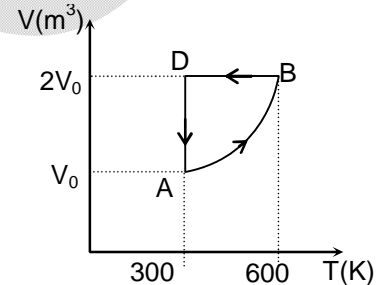

17. A particle of specific charge (charge/mass) α starts moving from origin under the action of an electric field $\vec{E} = E_0\hat{i}$ and magnetic field $\vec{B} = B_0\hat{k}$ the velocity of charge particle at (x, y) is $4\hat{i} + 3\hat{j}$. The x-coordinate of charge particle is given as $\frac{K}{4\alpha E_0}$. Find the value of K .

Chemistry

PART – II

SECTION – A

(One Options Correct Type)

This section contains **FOUR (04)** questions. Each question has **FOUR** options (A), (B), (C) and (D). **ONLY ONE** of these four options is the correct answer.

18. Choose the **INCORRECT** statement regarding Vanillin

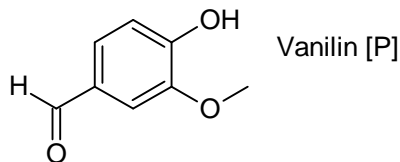

- (A) [P] can be obtained as a major product when 3,4-dihydroxy benzaldehyde is treated with one equivalent of NaOH and one equivalent of MeBr.
 (B) [P] can be obtained as a one of the product when 2-methoxy phenol is treated with chloroform and aq. KOH.
 (C) Position isomer of [P] can be obtained when 3,4-dihydroxy benzaldehyde is treated with one equivalent of NaOH and one equivalent of MeBr.
 (D) [P] can be obtained when 3,4-dihydroxy benzaldehyde is treated with two equivalent of NaOH and one equivalent of MeBr followed by acidic work up.
19. Which of the following compound will **NOT** show geometrical isomerism?

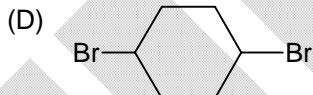
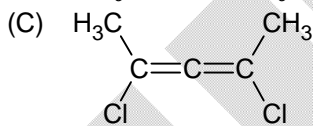
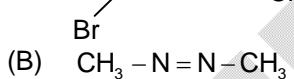
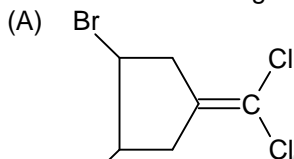

- 20.

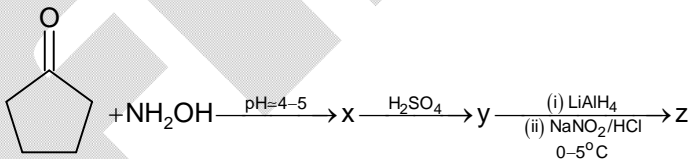

Which option is correct?

- (A) x is α -amino ketone
 (B) y is cyclic amide
 (C) z is yellow oily liquid
 (D) both B and C are correct

21. Choose the **CORRECT** statement for the given reaction scheme

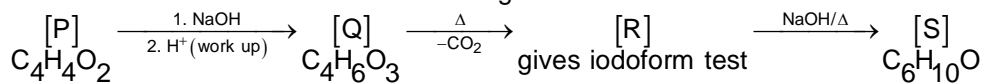

Unsaturated

Lactone

- (A) [S] is an α, β - unsaturated aldehyde.
 (B) Four stereoisomers are possible for [S].
 (C) Two structural isomers of [P] can satisfy the above reaction scheme.
 (D)

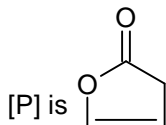

SECTION – A

(One or More than one correct type)

This section contains **THREE (03)** questions. Each question has **FOUR** options (A), (B), (C) and (D). **ONE OR MORE THAN ONE** of these four option(s) is (are) correct answer(s).

22. Which of the following is/are the chain isomers of

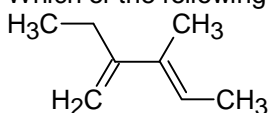

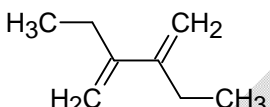
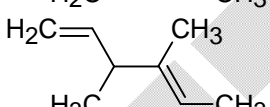
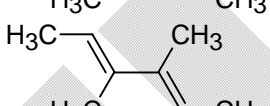
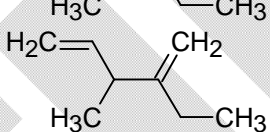
- (A) 
- (B) 
- (C) 
- (D) 

23. Which of the following statement(s) is/are correct about polymers?

- (A) Neoprene is a polymer of isoprene.
 (B) Glyptal is a condensation polymer of ethylene glycol and phthalic acid.
 (C) Terylene is a condensation polymer of ethylene glycol and terephthalic acid.
 (D) Nylon-6,6 is a condensation polymer of hexamethylenediamine and adipic acid.

24. Choose the **CORRECT** statement(s) about the following alkenes is/are

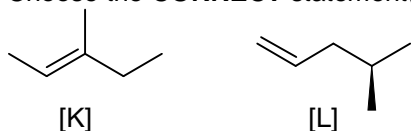



- (A) Alkene [K] is more stable than alkene [L].
 (B) Hydrogenation of achiral alkene [K] will give chiral product.
 (C) Hydrogenation of achiral alkene [L] will give chiral product.
 (D) The two alkenes [K] and [L] are structural isomers.

SECTION – A
(Matching List Type)

This section contains **FOUR (04)** Matching List Type Questions. Each question has **FOUR** statements in **List-I** entries (P), (Q), (R) and (S) and **FIVE** statements in **List-II** entries (1), (2), (3), (4) and (5). The codes for lists have choices (A), (B), (C), (D) out of which **ONLY ONE** of these four options is correct answer.

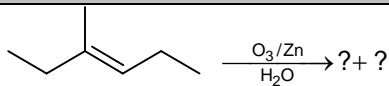
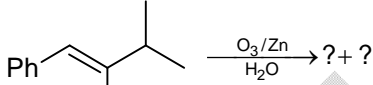
25. Match each species in List – I with their properties in List-II and choose correct option

List – I		List – II (Products can be distinguished by)	
(P)		(1)	Fehling's test
(Q)		(2)	Tollen's test
(R)		(3)	Iodoform test
(S)		(4)	Schiff's test
		(5)	Benedict's test

- (A) P → 1,2,3,4,5; Q → 2,3,4; R → 3; S → 1,2,4,5
 (B) P → 1,2,3,4; Q → 1,2,3; R → 3,4; S → 1,2,4,5
 (C) P → 2,3,4,5; Q → 2,3; R → 4; S → 1,2,4
 (D) P → 3,4,5; Q → 1,3; R → 2,4; S → 2,4,5

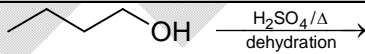
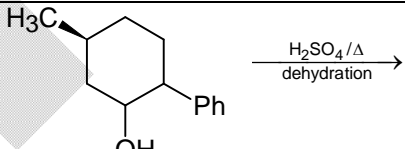
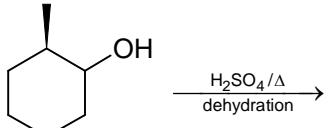

26. Match each species in List – I with appropriate statement (s) of List – II and choose correct option

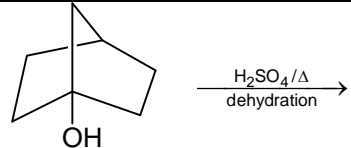
List – I		List – II	
(P)		(1)	At least one of the product shows optical isomerism.
(Q)		(2)	Major product contains even number of α – hydrogens (Hydrogens which can involve in hyperconjugation).
(R)		(3)	One of the product shows geometrical isomerism.

(S)		(4)	Reactant can turn acidified dichromate to green.
		(5)	Will not undergo dehydration.

- (A) P → 2,3; Q → 2,3,5; R → 1,4; S → 5
 (B) P → 2,3,4; Q → 2,3,4; R → 1,2; S → 3,4
 (C) P → 2,3,4; Q → 1,2,3,4; R → 1,4; S → 5
 (D) P → 1,2,3,4; Q → 2,3,4; R → 1,3; S → 2

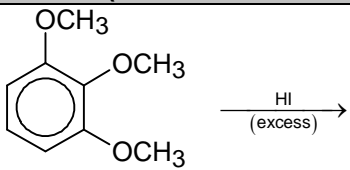
27. Match each species in List – I with appropriate statement(s) in List – II and choose correct options:

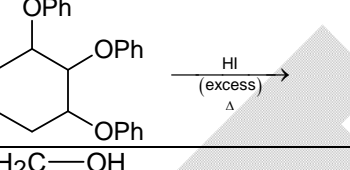
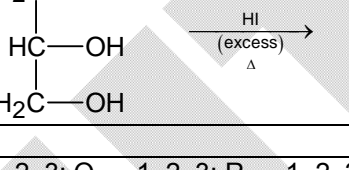
List – I (One mole of reactant)		List – II	
(P)		(1)	More than 4 moles of HI will be consumed.
(Q)		(2)	One of the product will react with Na/dry ether.
(R)		(3)	Product formed contains 2° halide.
(S)		(4)	CH ₃ I is one of the product.
		(5)	2-Iodopropane is a major product.

- (A) P → 2, 3; Q → 1, 2, 3; R → 1, 2, 3; S → 2, 4, 5
 (B) P → 1, 5; Q → 2, 3, 4; R → 1, 2, 3, 5; S → 1, 2, 3
 (C) P → 2, 4; Q → 1, 2, 3, 4; R → 1, 2, 3; S → 1, 2, 3, 5
 (D) P → 1, 2; Q → 2, 4, 5; R → 1, 2, 3; S → 2, 3, 5

28. Match each species in List – I with List – II and choose correct option

List – I		List – II	
(P)	A carbohydrate which yields only glucose on hydrolysis	(1)	Sucrose
(Q)	A carbohydrate which yields glucose and fructose on hydrolysis	(2)	Lactose
(R)	A carbohydrate which yields glucose and galactose on hydrolysis	(3)	Amylose
(S)	A carbohydrate which can reduce Fehling's solution	(4)	Mannose
		(5)	Cellulose

- (A) P → 3, 5; Q → 2; R → 1; S → 2, 4
 (B) P → 3, 5; Q → 1; R → 2; S → 2, 4
 (C) P → 3; Q → 1; R → 2; S → 1
 (D) P → 5; Q → 2; R → 2; S → 2

SECTION – B

(Numerical Answer Type)

This section contains **SIX (06)** Numerical based questions. The answer to each question is a **NON-NEGATIVE INTEGER VALUE**.

29. 'A' is an optically active hydrocarbon with minimum molecular weight ('A' does not have any isotopic atoms like D and C¹⁴).

If (a) Number of carbon atoms in A = x.

(b) Degree of unsaturation = y.

Calculate x + y

30. Consider the following reaction:

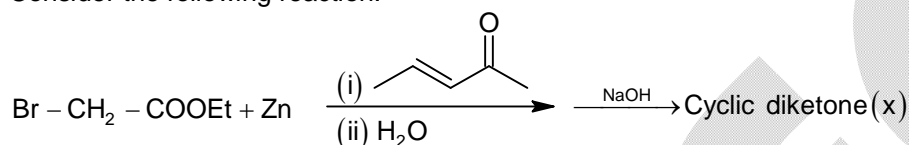

If (x) is finally treated with excess of NaBH₄ followed by acid work-up, the number of diols formed (including stereoisomers) is (y). Then, calculate the value of 5y.

31. Choose the appropriate reagent sequence from the given reagent pool to complete the synthetic conversion. Make sure to use strictly four reagents, not more not less.

Note: You can simply mention the numerical values corresponding to the reagent in the boxes P, Q, R, S respectively and also consider major organic product in each step.

What is the value of [P + R + S + Q].

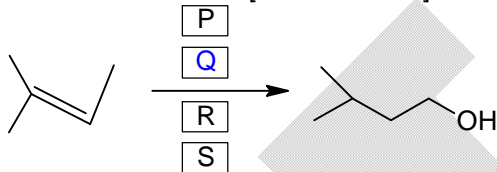

- | | | | |
|----------------------|---|---|-------------------------|
| 1. HBr | 2. H ⁺ / H ₂ O | 3. Hg(OAc) ₂ / H ₂ O | 4. BH ₃ .THF |
| 5. EtONa / EtOH / Δ | 6. HBr / ROOR / Δ | 7. conc. H ₂ SO ₄ / Δ | |
| 8. NaBH ₄ | 9. H ₂ O ₂ , aq. NaOH | 10. t-BuOK / Δ | |

32. [A] is a monomer of natural rubber, on reaction with HBr (1 eq)/CCl₄ at 298 K, it forms major product [B] (thermodynamically stable product).

The number of allylic hydrogen of [B] is y, the value of (y)?

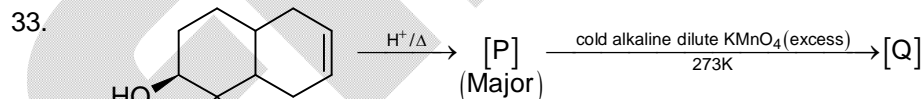

Calculate the sum of secondary and tertiary hydroxyl groups in [Q]

34. Number of chiral carbon atoms in α-D (+) glucose is x. Then calculate the value of 100x

Mathematics**PART – III****SECTION – A****(One Options Correct Type)**

This section contains **FOUR (04)** questions. Each question has **FOUR** options (A), (B), (C) and (D). **ONLY ONE** of these four options is the correct answer.

35. The minimum value of $3 \sin x + 5 \sin^2 x + 4 \operatorname{cosec} x + 6 \operatorname{cosec}^2 x$, for $x \in \left(0, \frac{\pi}{2}\right]$ is
- (A) $2(\sqrt{12} + \sqrt{30})$ (B) $4(360)^{1/4}$
 (C) 18 (D) $2(\sqrt{18} + \sqrt{20})$
36. Let C_1 & C_2 be two circles which touch each other externally and the equation of pair of direct common tangents to them is given by $x^2 + 2\sqrt{15}xy + 3y^2 + 3x - 5y + c = 0$. If radius of C_1 is 1 unit, and area of C_2 is greater than area of C_1 , then radius of C_2 is _____ (Given C_1 & C_2 are between the region contained between the acute angle of the given lines)
- (A) $\sqrt{2}$ (B) $\sqrt{3}$
 (C) 2 (D) 3
37. In $\triangle ABC$, $BC > AB > AC$. The incircle of the triangle touches BC at M. The excircle of the triangle tangent to BC touches BC at N. If perimeter of $\triangle ABC$ is 20 cm, $MN = 2$ cm, $BC = 8$ cm, and r is the inradius of the triangle ABC, then $r \times \tan B = ?$
- (A) $\frac{15}{11}$ (B) $\frac{6}{5}$
 (C) $\frac{15}{7}$ (D) 3
38. P & Q are two points on $\frac{x^2}{a^2} - \frac{y^2}{b^2} = 1$, such that $OP = \sqrt{2}$, $OQ = \sqrt{3}$ & $PQ = \sqrt{5}$, where 'O' is the origin. If the eccentricity of the hyperbola is $\sqrt{6}$, then the area of triangle formed by the tangent at P & asymptotes of the hyperbola is
- (A) $\frac{24}{5\sqrt{5}}$ (B) $\frac{12}{5\sqrt{2}}$
 (C) $\frac{24}{\sqrt{5}}$ (D) $\frac{12}{5}$

SECTION – A

(One or More than one correct type)

This section contains **THREE (03)** questions. Each question has **FOUR** options (A), (B), (C) and (D). **ONE OR MORE THAN ONE** of these four option(s) is (are) correct answer(s).

39. If $\cos \theta$ satisfies $16x^4 - 8x^3 - 12x^2 + 4x + 1 = 0$, where $0 < \theta < \pi$. Then which of the following statements is/are true?
 (A) There are exactly four distinct values of θ which satisfy the above
 (B) The largest possible θ that satisfies the above is greater than $(1 + \sqrt{2})$ radians
 (C) The smallest possible θ that satisfies the above is less than $\left(\frac{1}{3}\right)$ radians
 (D) All such ' θ ' also satisfy $8 \sin\left(\frac{\theta}{2}\right) \sin\left(\frac{5\theta}{2}\right) \cos(\theta) = 1$
40. ABCD is a parallelogram such that equations of diagonals BD and AC are $4x - 3y + 2 = 0$ and $5x - 12y + 19 = 0$ respectively. If area (ABCD) = 264 unit² and BD = 20 units, then the vertices of the parallelogram may be
 (A) (-5, -6) (B) (-7, 10)
 (C) (25, -12) (D) (-23, -8)
41. Let the reflection of the ellipse $\frac{x^2}{9} + \frac{y^2}{4} = 1$ across the mirror $y = 2x$ be given by $ax^2 + by^2 + 2hxy = c$, where a & b are co-prime natural numbers. Then which of the following are true?
 (A) $a + b + c + h = 256$ (B) $c = 5a$
 (C) $b = h + 5$ (D) $c = 15h$

SECTION – A

(Matching List Type)

This section contains **FOUR (04)** Matching List Type Questions. Each question has **FOUR** statements in **List-I** entries (P), (Q), (R) and (S) and **FIVE** statements in **List-II** entries (1), (2), (3), (4) and (5). The codes for lists have choices (A), (B), (C), (D) out of which **ONLY ONE** of these four options is correct answer.

42. Let the lines $L_1 : 3x + 4y = 7$, $L_2 : 5x - 12y = -7$ and $L_3 : x - 8y = 21$ form a ΔABC , where A is the intersection of L_1 and L_2 , B is the intersection of L_2 and L_3 & C is the intersection of L_3 and L_1 . Let $P(\alpha, \beta)$ be a point on line $L_4 : x = 4y$, then in which interval will β always lie in if

List – I		List – II	
(P)	P is closer to point A than B or C	(1)	$\left(\frac{7}{31}, \frac{3}{4}\right)$
(Q)	P is closer to line AC than AB	(2)	$\left(\frac{3}{16}, \frac{3}{8}\right)$
(R)	$Ar(\Delta APB) + ar(\Delta BPC) > ar(\Delta APC)$	(3)	$\left(\frac{-135}{106}, \frac{27}{26}\right)$
(S)	P is strictly inside ΔABC	(4)	$\left(-\frac{7}{8}, \frac{7}{16}\right)$
		(5)	$\left(\frac{-21}{16}, \frac{35}{16}\right)$

The correct option is:

- (A) (P) \rightarrow (1); (Q) \rightarrow (2); (R) \rightarrow (5); (S) \rightarrow (3)
 (B) (P) \rightarrow (5); (Q) \rightarrow (1); (R) \rightarrow (3); (S) \rightarrow (4)
 (C) (P) \rightarrow (3); (Q) \rightarrow (2); (R) \rightarrow (1); (S) \rightarrow (4)
 (D) (P) \rightarrow (3); (Q) \rightarrow (1); (R) \rightarrow (5); (S) \rightarrow (4)

43. From a point (40, 40), three distinct normals are drawn to $y^2 = 4x$. A circle passing through points of intersection of normals and parabola meets parabola at four points

List – I		List – II	
(P)	The abscissa of centre of the circle is	(1)	10
(Q)	The ordinate of the centre of the circle is	(2)	16
(R)	The closest integer to the radius of the circle is	(3)	21
(S)	The abscissa of the fourth point common to the parabola and circle (apart from the intersection of normals & parabola) is	(4)	23
		(5)	0

The correct option is:

- (A) (P) \rightarrow (4); (Q) \rightarrow (2); (R) \rightarrow (3); (S) \rightarrow (1)
 (B) (P) \rightarrow (3); (Q) \rightarrow (1); (R) \rightarrow (4); (S) \rightarrow (5)
 (C) (P) \rightarrow (4); (Q) \rightarrow (1); (R) \rightarrow (3); (S) \rightarrow (5)
 (D) (P) \rightarrow (3); (Q) \rightarrow (2); (R) \rightarrow (4); (S) \rightarrow (1)

44. A particle is moving around the circle $x^2 + y^2 + 4x - 6y + 3 = 0$. The particle leaves the circle at (1, 2) tangential to it. It strikes the mirror $y = mx + c$, gets reflected as per laws of reflection, and then passes through the centre of the original circle. The perpendicular distance of $y = mx + c$ from (1, 2) is 5 units. Then acute angle between the incident ray and reflected ray is 2α , then

List – I		List – II	
(P)	Possible value of m is	(1)	$2 + 5 \operatorname{cosec}(\alpha - \tan^{-1} 3)$
(Q)	Possible value of $c - 2$ is	(2)	$-\cot(\alpha - \tan^{-1} 3) + 5 \operatorname{cosec}(\alpha - \tan^{-1} 3)$
(R)	Possible value of the ordinate of the point on the mirror where abscissa is 1 is	(3)	$\cot(\alpha - \tan^{-1} 3)$
(S)	Value of $\tan \alpha$ is $\sqrt{\frac{a-b}{c}}$, where a, b, c are co-prime natural numbers, then $\cot(\alpha + \tan^{-1}(a-b)) - \tan(a-b-c)$ is	(4)	$\cot(\alpha + \tan^{-1} 3)$
		(5)	$5 \operatorname{cosec}(\alpha + \tan^{-1} 3)$

The correct option is:

- (A) (P) \rightarrow (3); (Q) \rightarrow (2); (R) \rightarrow (5); (S) \rightarrow (4)
 (B) (P) \rightarrow (4); (Q) \rightarrow (5); (R) \rightarrow (1); (S) \rightarrow (3)
 (C) (P) \rightarrow (3); (Q) \rightarrow (2); (R) \rightarrow (1); (S) \rightarrow (4)
 (D) (P) \rightarrow (4); (Q) \rightarrow (2); (R) \rightarrow (5); (S) \rightarrow (3)

45. Let PQRST be a regular hexagon of maximum possible area which is inscribed in an ellipse E such that P, Q, S, T lie on the boundary of the ellipse, and R and U coincide with the foci of the ellipse. Let the length of semi-major axis of E be a. Then

List – I		List –II	
(P)	Length of longest diagonal of PQRST is	(1)	$(\sqrt{3} - 1)a$
(Q)	Length of latus rectum of E is	(2)	$(2\sqrt{3} - 2)a$
(R)	Ratio of area of hexagon to the area of E is given as $\frac{3^{\frac{5}{4}}}{2^{\frac{1}{2}}\pi} \cdot k$. Then $(a \times k)$ equals	(3)	$(2 - \sqrt{3})a$
(S)	Let θ be the acute angle between PQ and the tangent to E at Q, then $(a \times \tan \theta)$ is	(4)	$(2\sqrt{3} - 3)a$
		(5)	$(4\sqrt{3} - 6)a$

The correct option is:

- (A) (P) → (2); (Q) → (4); (R) → (5); (S) → (1)
 (B) (P) → (2); (Q) → (5); (R) → (1); (S) → (3)
 (C) (P) → (1); (Q) → (2); (R) → (5); (S) → (3)
 (D) (P) → (3); (Q) → (4); (R) → (2); (S) → (1)

SECTION – B

(Numerical Answer Type)

This section contains **SIX (06)** Numerical based questions. The answer to each question is a **NON-NEGATIVE INTEGER VALUE**.

46. Let $3x + 4y = 7$ be tangent to an ellipse with foci P(1, -1) and Q(2, -2) at point A. The value of $\frac{5}{\sqrt{2}}(PA + QA)$ is equal to
47. Number of integral values of x in the interval $[0, 5\pi]$ which satisfy $\cos^9 x - \sin^9 x < 5(\sin^5 x - \cos^5 x)$ is _____
48. Let N be the number of lattice points strictly inside the auxiliary circle of $\frac{x^2}{36} - \frac{9y^2}{400} = 1$ such that two distinct tangents can be made on the hyperbola from that point and the points of contact of the tangents with the hyperbola are in the third and fourth quadrants. Then the value of N is _____.
 ((x, y) is called a lattice point if $x \in \mathbb{Z}$ & $y \in \mathbb{Z}$).
49. In ΔABC , let 'I' be the incentre and 'O' be the circumcenter (lying inside the triangle). If B, I, O, C are concyclic points, $AB = 4$ and $BC = 5$, then area of ΔABC is given by $(\sqrt{12} + \sqrt{n})$ unit², where 'n' is a natural number. Value of n is _____
50. Let ABCD be convex quadrilateral. P_1 is a parabola having focus at A and is tangent to lines BC & CD at E & F respectively. P_2 is another parabola having focus at C and is tangent to lines AB & AD at G & H respectively. Also, BD is tangent to P_1 at I & tangent to P_2 at J, such that $BI < BJ < BD$. If $BI = 7$, $IJ = 4$, then $BD = ?$
51. If $\tan x + \tan^2 x + \tan^3 x = 1$, then the value of $10 \cos^2 x(2 - \sin^2(2x))$ equals